



TECHNICAL  
INSTALLATION  
MALUTI

APPROVAL

	NAME	SIGNATURE	POSITION	DATE
PREPARED BY:				
REVIEWERD BY:				
APPROVED BY:				

1.1. TECHNICAL INFORMATION

1.1.1. Power data

RATED POWER	100 – 200W
INPUT VOLTAGE RANGE	200 – 240 VAC 50/60Hz
INPUT TYPE (AC/DC)	AC – Alternating current
CONNECTED POWER	90 – 185W
POWER FACTOR	>0.9

1.1.2. LED data

LED BARND	CREE®, Luxeon® or Osram®
CCT	3000 – 5000 Kelvin
CRI	≥80
LED RATED LIFETIME	80 000 hours

1.1.3. Luminaire data

IP RATING	IP65
BEAM ANGLES	120° Diffused
DIMMABILITY	Optional
MOUNTING POSITION	Universal
MOUNTING HIGHT	4 – 12M

1.1.4. Luminaire physical characteristics

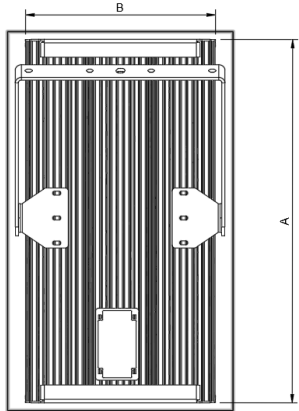
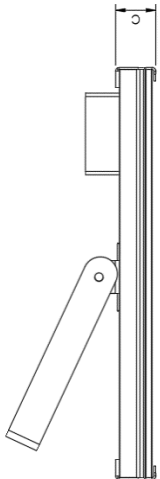
SERIES 5				
	100W	170W		
A (mm)	600	600		
B (mm)	103	206		
C (mm)	120	120		
Weight (kg)	3	6		
MAX projected Area (m <sup>2</sup> )	0.094	0.156		

SERIES 6			
	100W	150W	200W
A (mm)	600	600	530
B (mm)	103	206	310
C (mm)	120	120	120
Weight (kg)	3	6	7
MAX projected Area (m <sup>2</sup> )	0.094	0.156	0.193

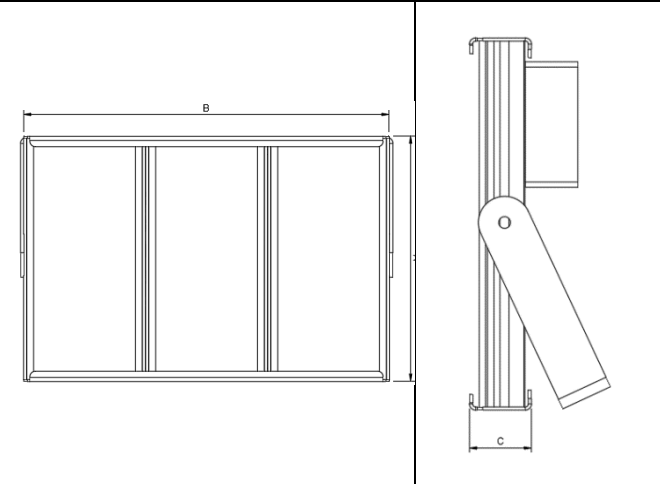

## 1.2. INSTALLATION INSTRUCTION

### 1.2.1. Part number break down.

Part no. example. HB-170-S5-C-M-U-2

LUMINAIRE DESCRIPTION	WATTAGE	SERIES	CCT-COLOUR TEMPERATURE	LENS	MOUNTING TYPE	NUMBER OF BANKS
HB - High Bay	100W, 150W, 170W, 200W,	S5 - SERIES 5 S6 - SERIES 6	W - 3000K - warm white N - 4000K - Neutral white C - 5000K - Cool white	D - 120°	U - U-bracket	1 - 2

### 1.2.2. Diagrams/drawings

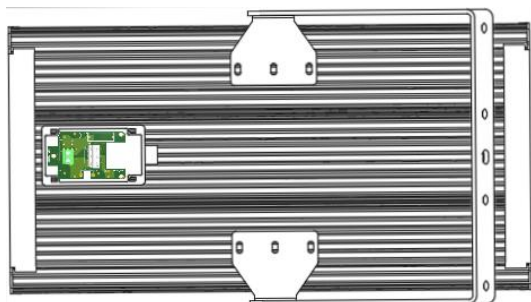

Figure 1 Back of high mast luminaire

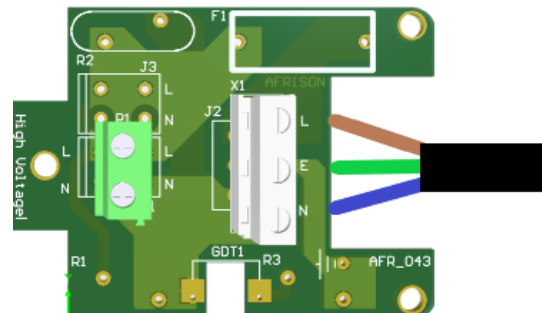

Figure 2 Protection unite diagram

### 1.2.3. Installation instructions

The Installation must be carried out by a Qualified Electrician in compliance with the local code of practice.

#### Tools required:

Flathead screwdriver 5.5mm (to open connection box)

17mm and 13mm spanner (to adjust U-Bracket)

## QMS PROCEDURE – TECHNICAL INSTALLATION MALUTI

Dependent on fasteners that will be used the tools may vary.

- Step 1. To install the Maluti high bay luminaire special attention needs to be given to the mounting holes on the U bracket for alignment.
- Use correct size (calculated on height and weight) Bolts/Rawl bolts to correspond with your mounting surface.
- Once u bracket adjusted to required angle fasten u bracket bolts. Series 5 luminaire (M10 – 55N.m) Series 6 luminaire (M8 – 25N.m).
- Step 2. To connect to the mains 220VAC confirm main power is switched off.
- Step 3. Maluti high bay luminaires require mains Voltage of between 200 to 240VAC 50 Hz. Connect the mains cable to the Protection unit via the 20mm Cable Gland. Always use round cable and not Flex or flat cables for sealing purposes with the Cable Gland. Open the Protection unit by unscrewing the 4 screws that keep the lid closed. Connect the corresponding wires, Brown (L), Blue (N), and Yellow/Green (E) on to the connector on the PC board, as shown in diagram above. Always read the label on the Protection Unit to make sure the Voltage is correct. When powering the light, the light should come on immediately, without any strike delay.